

HORIZONTAL painting PLANTS

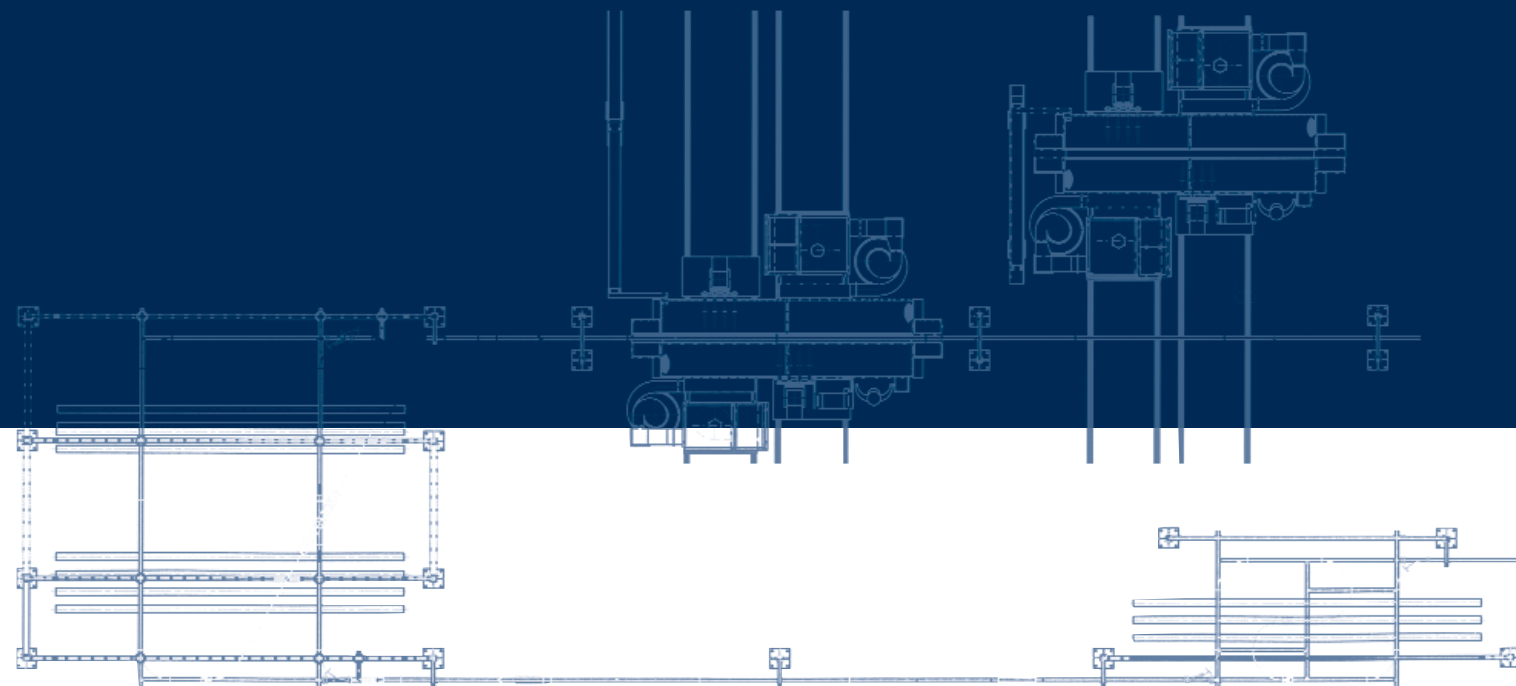

Otefal Ingegneria designs and manufactures a complete range of 'turnkey' systems for surface treatment and painting of metal products for all kinds of applications. We have a full range of innovative products to offer, resulting from all the experience accrued over the last 35 years in this sector.

Having full control over the process, right from the design stage and through all the production phases, is the best guarantee for the final quality of the systems.

Highly specialized engineers take charge of installing and commissioning, while assistance is provided during the stages for starting up and full-scale production.

Also training courses are provided for the staff who will be using the system.

HORIZONTAL
painting
PLANTS

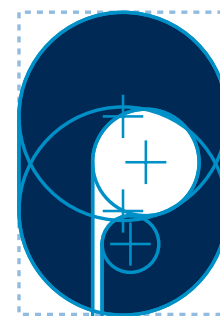

OTEFAL
INGEGNERIA

Via G. Di Vittorio, 21
25033 COLOGNE (BS)
Tel.: +39 0307050218
Fax: +39 0307050275
e-mail: oting@tin.it
otefalgroup.com

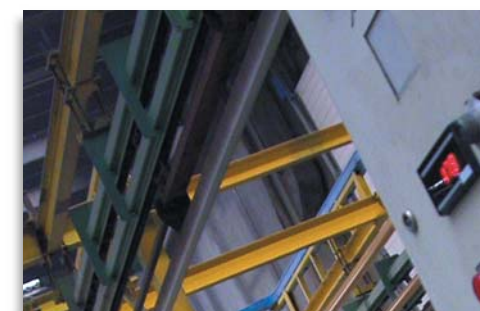

HORIZONTAL PLANTS

SECTIONS
PAINTING

HORIZONTAL PAINTING PLANTS

OTEFAL ENGINEERING DESIGNS AND CONSTRUCTS **HORIZONTAL PAINTING PLANTS** FOR METAL SECTIONS AND ALUMINIUM EXTRUSIONS.

FLEXIBLE PLANNING



The **power & free conveyor** carries the material from the loading zone through the various sections of the plant, through to the final unloading of the finished product, and it stockpiles product in the loading and unloading zones and inside the polymerisation oven. The features of the conveyor are established depending on the type of product that is being treated.

otefalgroup

For powder painting of aluminium extrusions, with a production capacity between 500 and 1100 kg/h, Otefal offers a range of horizontal painting systems that are designed and constructed on the basis of the customer's specific needs.

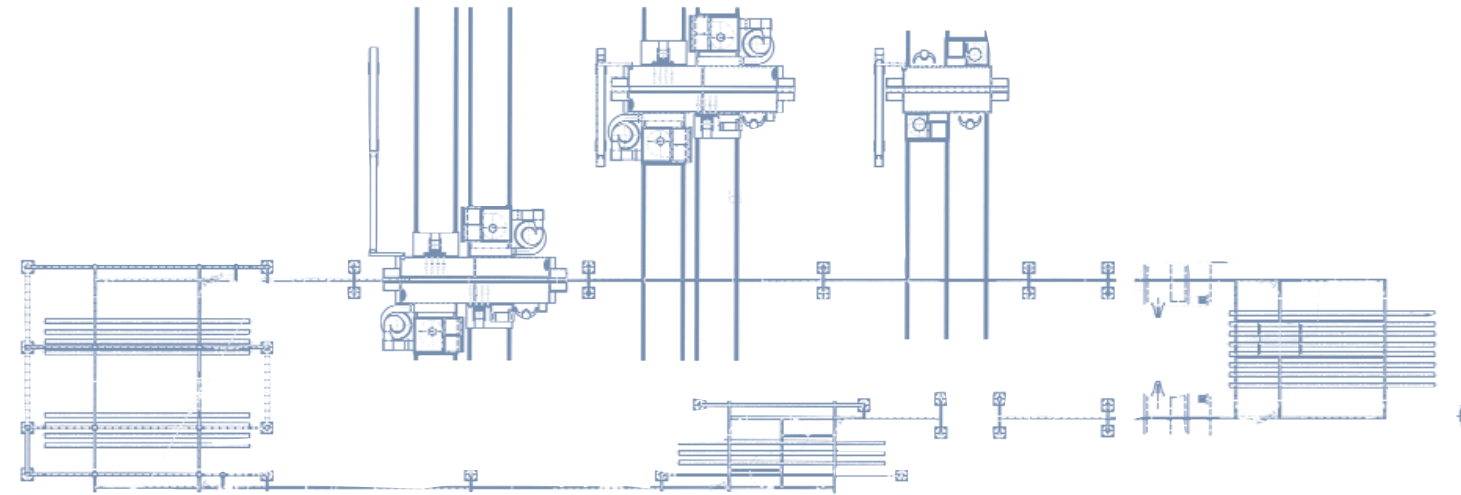

HORIZONTAL PLANTS



The booths can be automatic or manual: the configuration of the painting section is designed according to the production requirements:

- Single colour production or with sporadic colour changes: a single automatic booth; the overspray is recovered by the suction system, equipped with one or two cyclones and a cartridge filtering system at the end: the majority of the dust settles at the bottom of the cyclone and is sent to the powder hopper, which is fitted with a pneumatically operating sieve for sifting the powder before it is recycled, the small amount that is not recycled by the cyclone is sent through the self-cleaning cartridge filter and is collected in a bin ready for disposal; the bottom of the booth has an automatic cleaning mechanism; if required, access can be fitted to the booth for manual touch up if complex parts are involved..
- Production with several colour changes each day: automatic system with two sliding booths; the booths have the same features as the automatic booth for single-colour production, they run on rails and can be moved away from the painting line to a special cleaning area: this configuration means that one booth can continue operating while the other is being cleaned and prepared for the next colour, without risk of contaminating the sections during painting and virtually eliminating standstill due to colour changes.
- Production with several colour changes for average lots and with occasional painting needs for small lots or parts with complex configuration: two booths system with recovery by cyclones for automatic application (with space available for manual retouching) and a booth without recovery system for manual applications on small lots.

The curing ovens have hot air circulation: the oven configuration, airflow and heat exchanger capacity are designed to guarantee an even temperature in all the parts of the oven to guarantee an identical final appearance for all the parts; to reduce heat dispersion to a minimum, the structure is insulated and the oven openings have air curtains.

On request, powder pre-gelling zones can be installed using catalytic panels which reduce the total time spent inside the oven.